

Fantech Jetstream

Ø150mm Spigot



CONTENTS & INSTALLATION INSTRUCTIONS

Contents:

Jetstream Fan	1 off.
Mounting Bracket	1 off.
Fixing screws	4 off.
Installation Instruction	1 off.

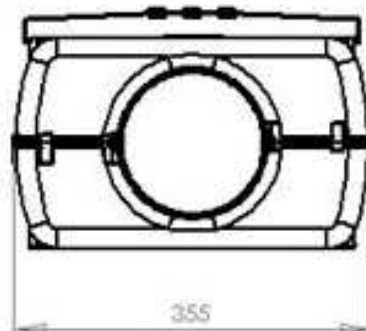
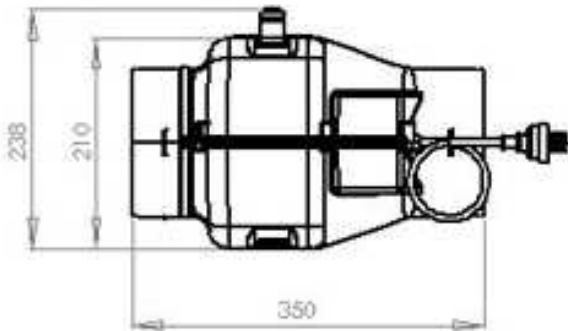
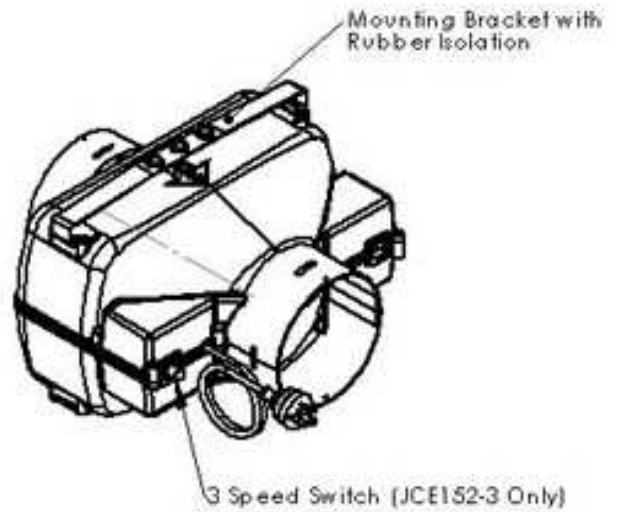
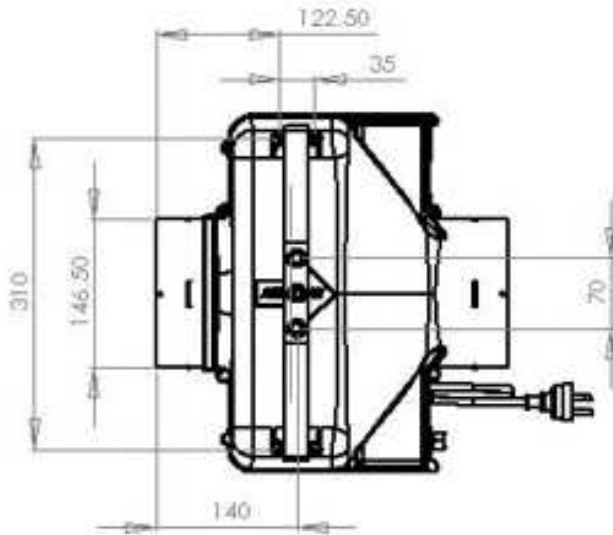

Installation:

1. Installation of this product should be carried out by appropriately qualified persons.
2. Ensure the unit has arrived in good condition and that the impeller is free to rotate.
3. The Jetstream Fan can be installed in one of two ways:
 - A). Fix the mounting bracket where the fan will be installed and snap the fan into the bracket.
Ensure Backdraft Damper is positioned correctly.
 - B). Utilise the four holes and four screws provided to fix the fan appropriately. Ensure Backdraft Damper is positioned correctly.

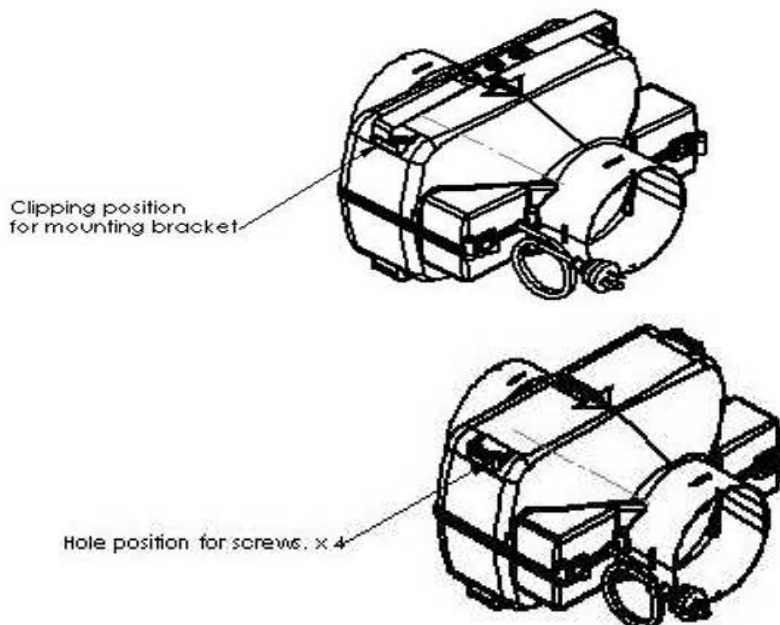

4. If not required, the Backdraft Damper can be removed by removing the clips.
5. Plug fan into 240V AC power point.

Safety Considerations:

1. All connections must be in accordance with any local regulations.
2. Licensed Electrical installer must ensure that an approved means of disconnection be incorporated into the fixed wiring.
3. Fans have non self-resetting thermal cut-out switches incorporated in the motor as standard.
4. This appliance is not intended for use by young children or infirm persons unless they have been adequately supervised by a responsible person to ensure that they can use the appliance safely.
5. Do not operate if the supply cord or plug has been damaged. Please return to manufacturer or service agent for repair.
6. Do not fit any screws through the Back Draft Damper for interference reasons.
7. For duct or partition mount, precautions must be taken to avoid the back-flow of gases into the room from the open flue of gas or other open-fire appliances.
8. Fan is to be fitted with a minimum of 1 meter ducting on the inlet and outlet to prevent accidental contact with the fan blades.

WARRANTY:

- Fantech Pty Ltd warrants products of its manufacture when not misused or neglected to be free of defects in workmanship and/or materials. Our obligation under this warranty is limited to repairing or exchanging F.O.B. factory, any part, assembly or portion found to be defective within one year from the date of commissioning but not to exceed eighteen (18) months from date of shipment from our factory.
- The Company assumes no responsibility for labour costs involved in the removal of defective parts, installation of new parts or related service charges.
- The Company shall have the option of requiring the return of the defective part (transportation prepaid by the Buyer) to establish the claim.
- Warranty will be void if installation is not carried out by qualified personnel in accordance with these instructions and good trade practice.
- Fully detailed warranty conditions are contained in Fantech's Standard Conditions of Trading.