

FSU SERIES - AC SUPPLY



DESCRIPTION

The Filtered Supply Unit Series fan has been designed to provide filtered outside air to a range of applications. Can be wired in high, medium and low speed and includes a high performance cross flow impeller.

Typical Applications

Supplies filtered air for applications from switchrooms and dataroom pressurisation to libraries and classrooms. Also suitable for areas that are typically serviced by under-ceiling air conditioning units where a direct supply fresh air intake is not possible or practical.

Features

- Durable zinc coated steel housing, powder-coated 'off-white'.
- Designed for in-wall mounting.
- Strong and secure all steel construction.
- Weatherproof, inlet grille is standard.
- Powder-coated axial flow fan.
- 3-speed facility, connected on-site.
- G4 filter included as standard, see **Special Notes**.

Construction

Zinc coated, 'off-white' powder-coated steel housing. Integral all steel weatherproof inlet grille providing security. Filter in fan discharge is standard.

Motors

Type - external rotor, squirrel cage induction motor.
Electricity supply- 230V, single-phase, 50Hz.
Bearings - sealed-for-life, ball.
Supplied with three speed facility, adjusted on site by a wiring change or 3-speed switch - DSS1, refer to page A-29.
Class B motor, IP44 rated.
See pages O-2/3 for details on these motors.

Internal thermal Protection

Auto-reset type fitted as standard.

Testing

Air flow tests to BS848:Part 1, 1980
Noise tests to BS848:Part 2, 1985
Performances shown are based on clean filters.
As air flow will be affected by room pressurisation, care should be taken to ensure adequate air relief is provided.

DIMENSIONS

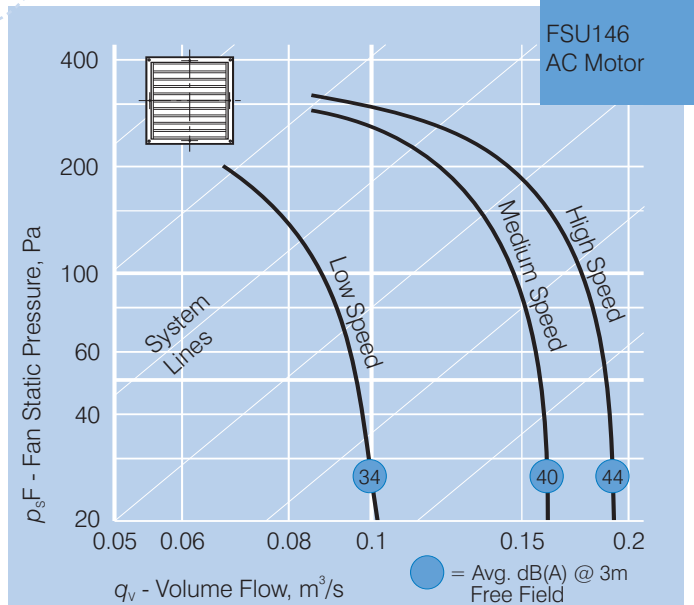
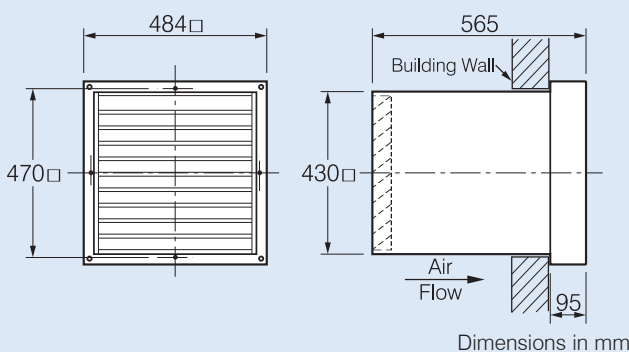

TECHNICAL DATA

Model Number	Speed Setting	Air Flow m³/sec	Avg. dB(A)* @ 3m	FSU.. 1 ph. Watts	App. Wt. kg
FSU146-4-B1	1 (Hi)	0.20	44	205	0.95
	2 (Med)	0.16	40		
	3 (Lo)	0.11	34		

* dB(A) figures shown are free field

Wiring Diagram

The unit is provided with a wiring strip mounted internally.

Active, Neutral and an Earth are required to be connected to the strip. On-Off switches are by others.

Wiring access is provided to allow wiring from inside the building. See page N-9, diagram ER11

Special Notes

Filter

A 420 x 420mm washable filter is provided on the discharge of the fan with a performance classification of G4 as tested in accordance with AS1324.2-2001 and rated as per AS1324.1-2001. These ratings are equivalent to the European 4/5 classification for filters as outlined in EN778. Access is obtained by un-doing four dome nuts on the diffuser panel and then turning four swivel clips.

Installation

This unit is designed to be installed flush to the inside wall, except diffuser plate protrusion. Four mounting holes are provided on the internal flange to secure the unit to the inside wall, fasteners are by others. A flashing angle can be provided for external use as an option. A penetration size of 440 x 440mm is required.

SUGGESTED SPECIFICATION

The Filtered Supply Unit shall be of the FSU Series fitted with an AC motor and supplied by Fantech Pty Ltd. The units shall incorporate a cross flow impeller and washable filter media in an 'off-white' powder-coated galvanised steel housing. Performance shall be based upon tests conducted to BS848:Part 1, 1980 for air flow and BS848:Part 2, 1985 for noise.



Scan the QR Code to view more information online.



HOW TO ORDER

Quote the model number shown in the technical data table.