

SAFETY INSTALLATION AND MAINTENANCE

INSTRUCTION FOR JETVENT WAREHOUSE VENTILATOR FANS

1.0 JET FAN WAREHOUSE VENTILATION

The jet fan ventilation system is designed to create “cross-flow” air movement across warehouse and factory work areas and along walkways. This method provides a noticeable “cooling effect” during higher ambient temperature conditions and also significantly improves the air quality by eliminating the build up of stagnant air and pollutants.

2.0 GENERAL

- 2.1 The detailed description of the fan unit supplied is shown on the attached nameplate. All further information should be checked and if in doubt, contact Fantech Pty Ltd. or the nearest agent.
- 2.2 All Fantech equipment must be installed by personnel who are trained in the appropriate discipline,
- 2.3 Also, a copy of this document must be available before attempting installation.
- 2.4 The guards / deflectors supplied with this product comply with AS 4024.1601:2006 & AS 4024.1801:2006.
- 2.5 It is important that the all Installation and maintenance Instructions are correctly and fully adhered to.
- 2.6 **Special note:** Prior to dispatch all fan units have been inspected and mechanically run. Due consideration is given to the smooth running of the unit, electrical power input and rotational speed. Therefore, Fantech Pty Ltd expects that if handled and installed professionally the goods will give long trouble free service.
- 2.7 It must also be noted that Jetvent fans are heavy (~80kg) and must be lifted carefully to prevent personal injury or damage to equipment
- 2.8 Ensure that the structure supporting the fan is sufficiently strong to secure the unit. Also ensure that adequate clearance is available for the air to enter and exit the fan. It is recommended that the holes for the anchor bolts are predrilled as per the fan footprint (see attached drawing) prior to lifting the fan assembly. Fantech Pty Ltd does not supply these fixings.

3.0 UPON RECEIPT

- 3.1 The fan and ancillaries should be visually inspected for any transit damage or loss. This includes the hand rotation of the impeller within the casing.
- 3.2 Should any damage, concern or technical queries result from these checks then Fantech Pty Ltd. or its agent should be contacted stating the fan type, Fantech invoice / contract number and serial number.
- 3.3 The electrical supply for the fan unit must be as specified on the fan nameplate subject to normal supply tolerance and design conditions. Full Load currents are indicated on the fan nameplate

4.0 STORAGE

- 4.1 If the fan is not to be used immediately, it should be stored in a clean dry place.
- 4.2 If the fan is to be subjected to any vibration in its stored location or is going for storage for longer than one month then Fantech Pty Ltd. or its agent should be consulted for special instruction in writing.

5.0 START UP

- 5.1 Once all electrical circuits have been checked with the connection diagram supplied – power may be supplied to the unit.
- 5.2 Upon initial start-up, ensure that the fan rotates in the correct direction. Confirm that the direction of fan discharge and installed location matches any schematic sketches or layouts.
- 5.3 Should it be suspected that the impeller is contacting the casing, the unit should not be run until a check is made to ensure that an adequate 'running clearance' exists between the casing and impeller. Also check that the gap is evenly spaced at various positions in the casing.
- 5.4 If the impeller needs centralization within the casing then it must be carried out prior to any further running.
- 5.5 A further run of about 30 minutes duration should be made so as to ensure smooth trouble free operation within the control circuits.
- 5.6 Once these check runs have been satisfactorily carried out and the equipment is checked to conform with essential Occupational Health and Safety (OH&S) requirements, then it can be considered to be adequately installed.

6.0 FAN MAINTENANCE

- 6.1 Due to the different periods of operation, no rigid inspection and maintenance period can be recommended. It is suggested therefore that inspection and, if necessary, fan cleaning (by non abrasive means) is carried out at regular intervals of at most 5,000 running hours or 12 months, whichever comes first.
- 6.2 All fastenings, of whatever type, should be checked for tightness. The integrity of the rotating items should be checked
- 6.3 Bearings are a 'sealed for life' type and hence will not need detailed inspection. The motor's cleanliness however must be checked, especially in relation to the cooling fan and/or fins, if fitted.
- 6.4 If it should be necessary to remove the impeller, then care must be taken and no undue force used. By removal of the central hub bolt and tab washer the impeller can be removed by pulling the outside diameter of the hub (Not the blade). Should the impeller fail to detach itself in this manner, please contact Fantech Pty. Ltd. or its agent for further advice.

7.0 JETVENT WAREHOUSE VENTILATOR - SPECIFICATIONS

Model no	JVWD6 JVWD6S	JVWE6 JVWE6S
Motor	415V / 50Hz / 3 phase	240V / 50Hz / 1 phase
High speed -	0.69kW, 1.45A	0.53, 2.5A
Low speed -	0.39kW, 0.79A	-
Volume flow rate	High speed -1200l/s Low speed - 900l/s Airflow tests were carried in accordance with ISO5810:2004.	
Discharge Air Velocity	High speed - 16m/s Low speed - 12m/s	
Noise levels	High speed - 64 dBA @ 3m Low speed - 55 dBA @ 3m	
Construction	Housing of galvanised sheet steel with internal scroll designed to maximise aerodynamic performance. Guarding is in accordance with AS4024.1801 – 2006 Safety of machinery.	

Dimensions

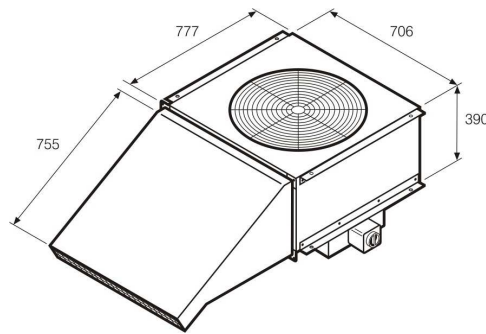

Weight	85kg
Installation	4 point suspension mount using 10mm threaded rod with guide wires as required.
Fan control	Three phase fans 2 speed star/delta controllable for high or low speed operation. Wiring is to be star/delta control only (Fantech SD1-S star/delta switch is recommended) Single phase units are single speed only

8.0 WAREHOUSE JETVENT: INSTALLATION SUGGESTIONS

8.1 Jetvent Warehouse Ventilation Fan – Support Layout Sketch

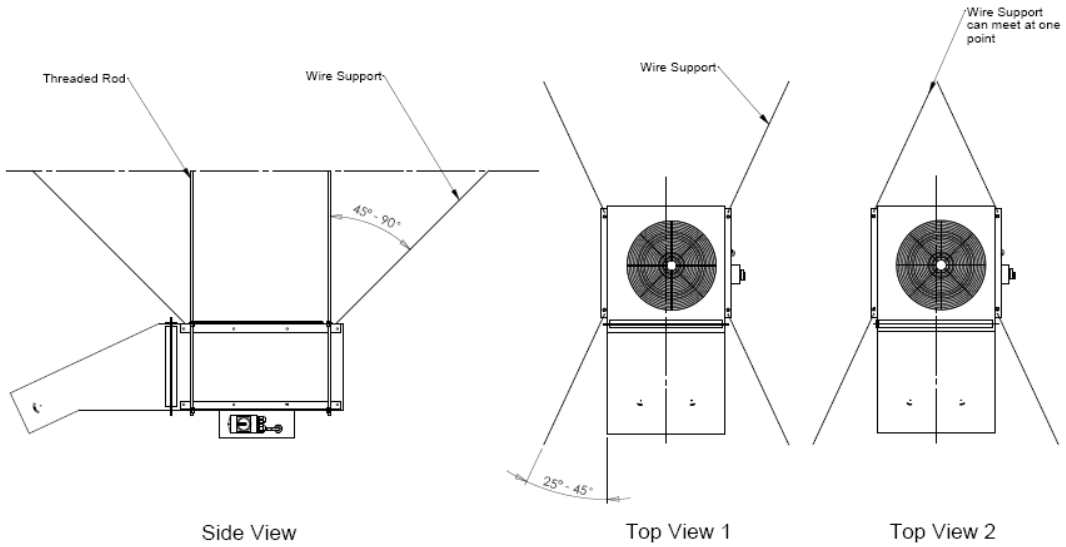

8.2 Jetvent Warehouse Ventilation Fan – Wiring Diagram

TWO SPEED STAR/DELTA MOTOR

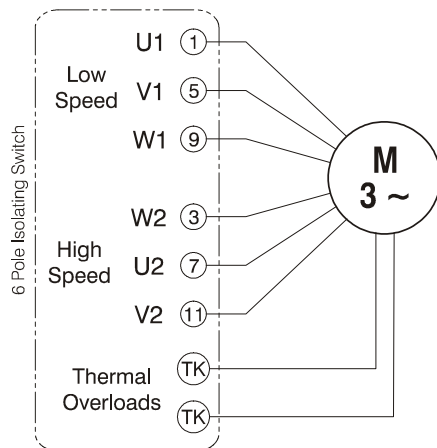

8.3 Jetvent Warehouse ventilation fan



8.4 JetVent Warehouse Ventilation fan – Representative Installation Photo

