



DESCRIPTION

The FlexLine Series of backward-curved centrifugal fans has been developed for ducted applications requiring high pressures.

They are available in various speed options and 8 sizes, extending from 315 to 710mm diameter.

Typical Applications

Commercial and industrial supply or exhaust applications requiring higher pressures for air filtration or long duct runs. These applications include shopping centres, office buildings, exhibition centres, hotels, health centres, schools and universities.

Features

- Single-width, single-inlet housings.
- Robust galvanised steel and aluminium construction.
- High efficiency, low noise backward-curved centrifugal impellers.
- Large choice of speeds available.
- Easy to fit 35mm TDF profile flange connections.
- To improve energy efficiency, motors can be speed-controlled.
- Motors complying with Ex d, Ex e, Ex nA and Ex tD. Standards can be fitted.

Construction

Galvanised steel housings with 35mm TDF profile flange connections and spun aluminium inlet cone.

Includes backward-curved centrifugal impellers.

Motors

Type - standard TEFC squirrel cage induction motors.

Electricity supply - three-phase to suit a wide range of voltages and frequencies

Bearings - sealed-for-life, ball.

The standard motors are speed-controllable using variable speed drives.

Multi-speed motors can be supplied

Motors to meet Ex d, Ex e, Ex nA and Ex tD standards can be fitted to some models.

See pages O-3/7 for details on these motors.

Internal Thermal Protection

Thermistors can be supplied on request.

Testing



Air flow tests to BS848:Part 1, 1980

Noise tests to BS848:Part2, 1985

Wiring Diagram

See pages N-6, diagrams DD 1, 2, 3 for standard frame motors.

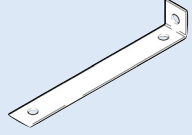
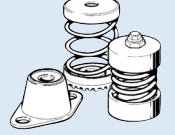
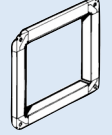
ANCILLARY EQUIPMENT

 <p>FLX - Mounting Feet Ref. E-6</p>	 <p>Vibration isolators Ref. I-1</p>	 <p>FLX.MF - Matching Flanges Ref. J-5</p>
 <p>Variable speed drives Ref. M-8/13</p>		

SUGGESTED SPECIFICATION

The duct mounted fans shall be of the FlexLine® Series as designed and manufactured by Fantech Pty Ltd and be of the model numbers shown on the schedule/drawings.

They shall include galvanised steel housings with 35mm TDF profile flange connections and spun aluminium inlet cones.

The backward-curved centrifugal impellers shall be driven by standard TEFC motors as nominated.

All models shall be fully tested as a complete assembled unit to BS848:Part 1, 1980 for air flow and BS848:Part 2, 1985 for noise.

HOW TO ORDER

Direct Drive

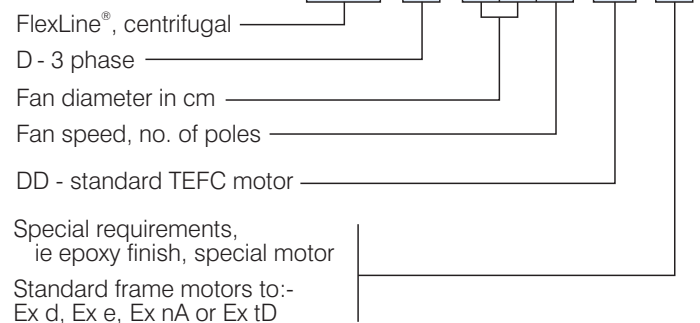

Scan the QR Code to view more information online.



FLEXLINE® SERIES - DIRECT DRIVE

Note

Performance curves shown are based on nominal speeds.

As motor speeds may vary from one manufacturer to another and from one motor type to another variations in performance can result.

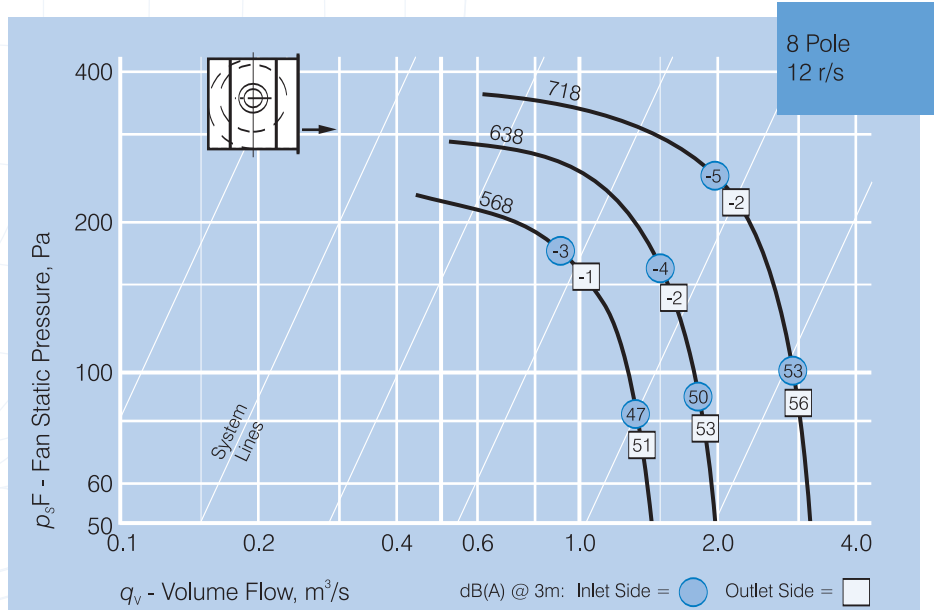
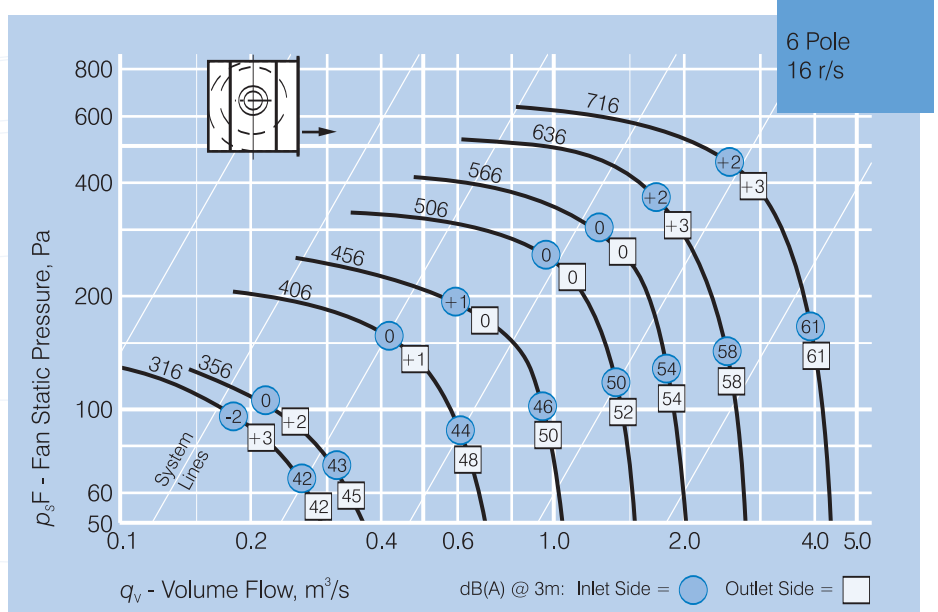
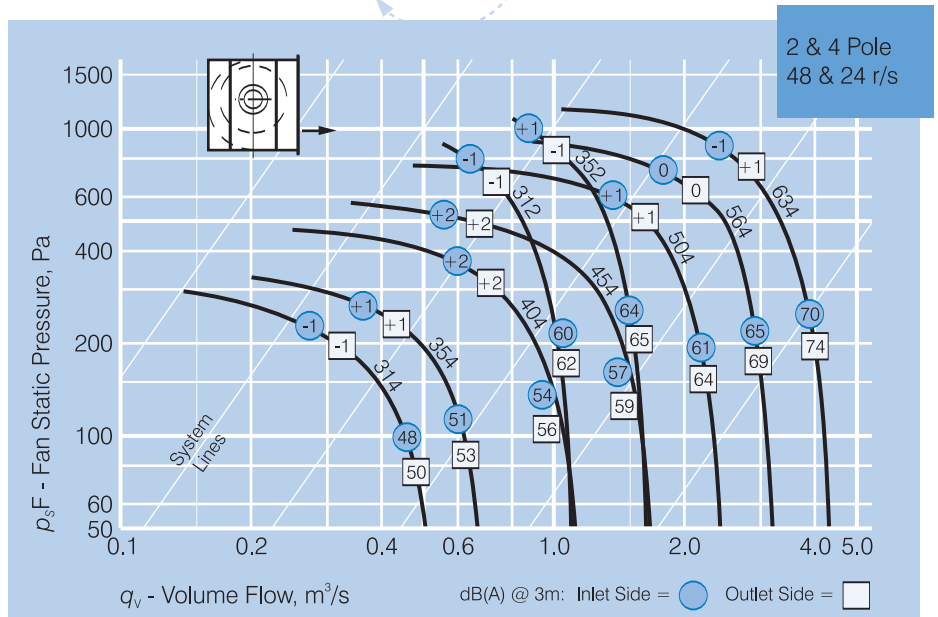

TECHNICAL DATA & NOISE DATA

Model FLD..DD	Nom. speed, rev/sec		Avg. dB(A) @ 3m		FLD..DD kW	3ph Amps*	In-Duct Spectrum Corrections, dB**							
			Low Air Flow	High Air Flow			63	125	250	500	1k	2k	4k	8k
312	48	Inlet	60	61	1.50	3.22	31	30	21	19	7	13	13	2
		Outlet	62	63			27	26	19	20	11	15	12	2
314	23	Inlet	48	49	0.55	1.38	34	28	20	17	9	9	7	1
		Outlet	50	51			30	24	18	18	13	11	6	-1
316	15	Inlet	41	43	0.37	1.10	33	25	21	17	11	11	5	-1
		Outlet	46	43			30	26	17	17	15	10	6	2
352	48	Inlet	66	65	2.20	4.30	23	26	21	19	6	14	15	2
		Outlet	63	66			20	28	16	8	13	17	13	2
354	23	Inlet	53	52	0.55	1.38	27	25	21	18	9	11	10	0
		Outlet	55	54			23	26	15	16	15	13	7	0
356	15	Inlet	44	44	0.37	1.10	32	24	21	18	13	7	2	-1
		Outlet	48	46			30	26	17	17	15	10	6	2
404	23	Inlet	57	55	0.55	1.38	27	25	20	17	10	11	11	4
		Outlet	59	57			25	25	16	16	15	12	9	5
406	15	Inlet	45	45	0.37	1.10	32	27	21	18	13	9	6	2
		Outlet	50	49			26	23	16	16	14	11	8	0
454	23	Inlet	60	58	0.75	1.80	26	24	19	16	10	11	11	7
		Outlet	62	60			27	23	16	16	15	11	10	9
456	15	Inlet	48	47	0.37	1.10	30	29	20	17	12	10	8	4
		Outlet	51	51			23	21	16	15	14	12	10	-1
504	23	Inlet	63	62	1.1	2.6	25	25	20	14	11	11	11	8
		Outlet	66	65			25	23	16	15	15	9	8	7
506	15	Inlet	51	51	0.55	1.70	29	28	21	15	11	9	7	5
		Outlet	53	53			26	24	17	16	15	12	10	1
564	23	Inlet	66	66	3.00	6.30	25	26	22	13	12	11	11	9
		Outlet	70	70			24	24	16	15	16	7	7	6
566	15	Inlet	55	55	1.10	2.90	28	28	22	14	11	9	7	6
		Outlet	56	56			29	26	18	16	15	11	9	2
568	11	Inlet	45	48	0.55	1.51	29	26	21	14	14	10	10	5
		Outlet	51	52			32	23	17	16	15	12	9	0
634	23	Inlet	70	71	4.00	8.03	23	27	23	11	12	10	11	9
		Outlet	76	75			23	26	17	15	17	6	6	6
636	15	Inlet	61	59	1.1	2.8	27	28	23	13	11	10	7	7
		Outlet	62	59			31	27	18	16	14	10	7	3
638	11	Inlet	47	51	0.55	1.51	27	26	22	13	13	8	9	5
		Outlet	52	54			33	23	17	16	15	10	8	-1
716	15	Inlet	64	62	2.20	5.14	27	28	23	13	11	9	7	7
		Outlet	65	62			31	27	18	16	14	10	7	3
718	11	Inlet	49	54	1.10	3.02	27	26	22	13	13	8	9	5
		Outlet	55	57			33	23	17	16	15	10	8	-1

* Amperages shown are a guide only, refer to our Sales Department for accurate figures at time of order.

** Add the In-Duct Spectrum Corrections from the table to the closest dB(A) level shown on the fan curve to obtain the In-Duct Sound Power Level. Note: there are noise levels for both the Inlet and Outlet Sides of the units.

FLEXLINE® SERIES - DIRECT DRIVE

DIMENSIONS

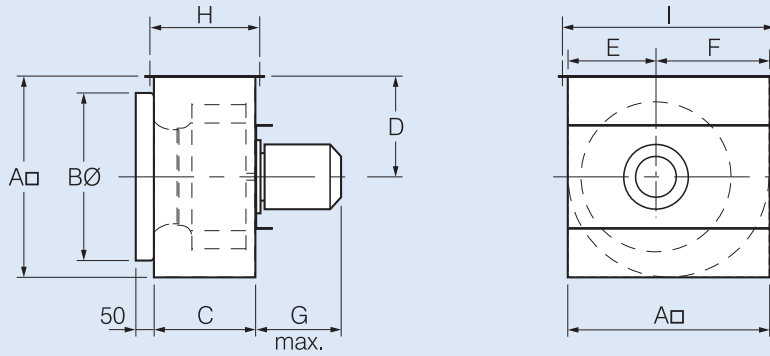

Model No. FLD..DD	Dimensions, mm			D	E	F	G max.	H	I	App. weight kg.	App.** vol. m³
	A□	B∅	C								
31.	425	361	212	213	179	246	280	246	458	42	0.10
35.	500	406	250	250	226	274	305	283	533	49	0.16
40.	550	455	275	275	240	310	245	308	583	49	0.18
45.	625	507	312	313	273	352	260	346	658	56	0.25
50.	700	564	350	350	316	384	280	383	733	65	0.36
56.	775	641	388	388	352	423	350	421	808	85	0.52
63.	850	722	425	425	388	462	400	458	883	99	0.70
71.	950	813	475	475	435	515	400	508	983	111	0.90

Dimension 'G' is approximate. Check with Fantech for dimension 'G' when space is critical.

Always allow sufficient space to remove the motor for maintenance.

**Based on maximum size standard motors.

MOUNTING FEET

FlexLine® mounting feet are available in either floor or ceiling mounted variations. Because of the range of mounting positions, refer to our sales department for details.

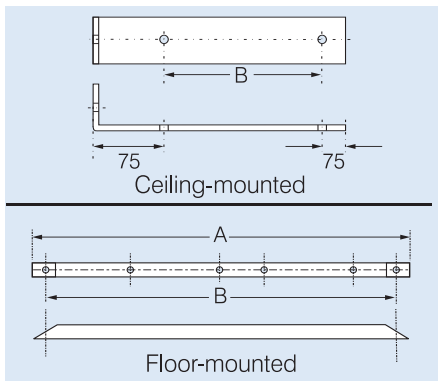

Ceiling Mounted

Model Number FLD..DD	Dimensions, mm B	Part No.
31.	170	FLX31FH
35.	210	FLX35FH
40.	230	FLX40FH
45.	270	FLX45FH
50.	300	FLX50FH
56.	340	FLX56FH
63.	370	FLX63FH
71.	430	FLX71FH

Floor Mounted

Model Number FLD..DD	Dimensions, mm A B		Part No.
31.	520	480	FLX31F
35.	600	560	FLX35F
40.	540	500	FLX40F
45.	580	540	FLX45F
50.	670	630	FLX50F
56.	720	680	FLX56F
63.	800	760	FLX63F
71.	830	790	FLX71F

MOUNTING ARRANGEMENTS

The illustrations below show the TEFC motor (DD) with type of mounting arrangement.

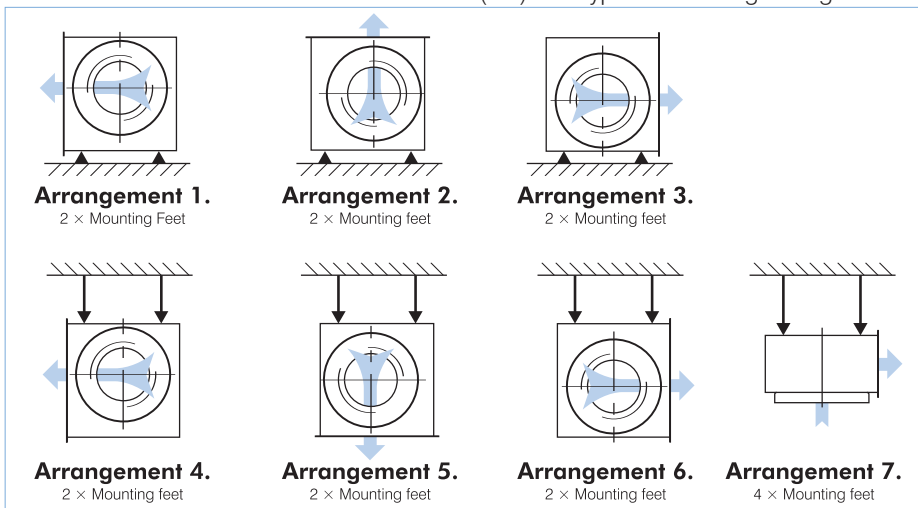

Mounting Feet are optional extras.